

FOR MASONRY WALLS:  
 3/16 x 1 1/2 x 8  
 STEEL ANCHORS  
 LOCATED ON 16"  
 CENTERS.

FOR MONOLITHIC WALLS:  
 1/2" DIA. x 6 1/8" H4L  
 CONCRETE ANCHORS ON 8"  
 CENTERS AT HEAD AND  
 SIDES

JAMISON FSR HINGE WITH BRONZE THRUST  
 BUSHINGS, 4 REQ'D. PER LEAF. HELD  
 WITH 1/2-13 NC X 1 1/4" LG. HEX  
 HEAD MACHINE BOLTS, 16 PER LEAF.

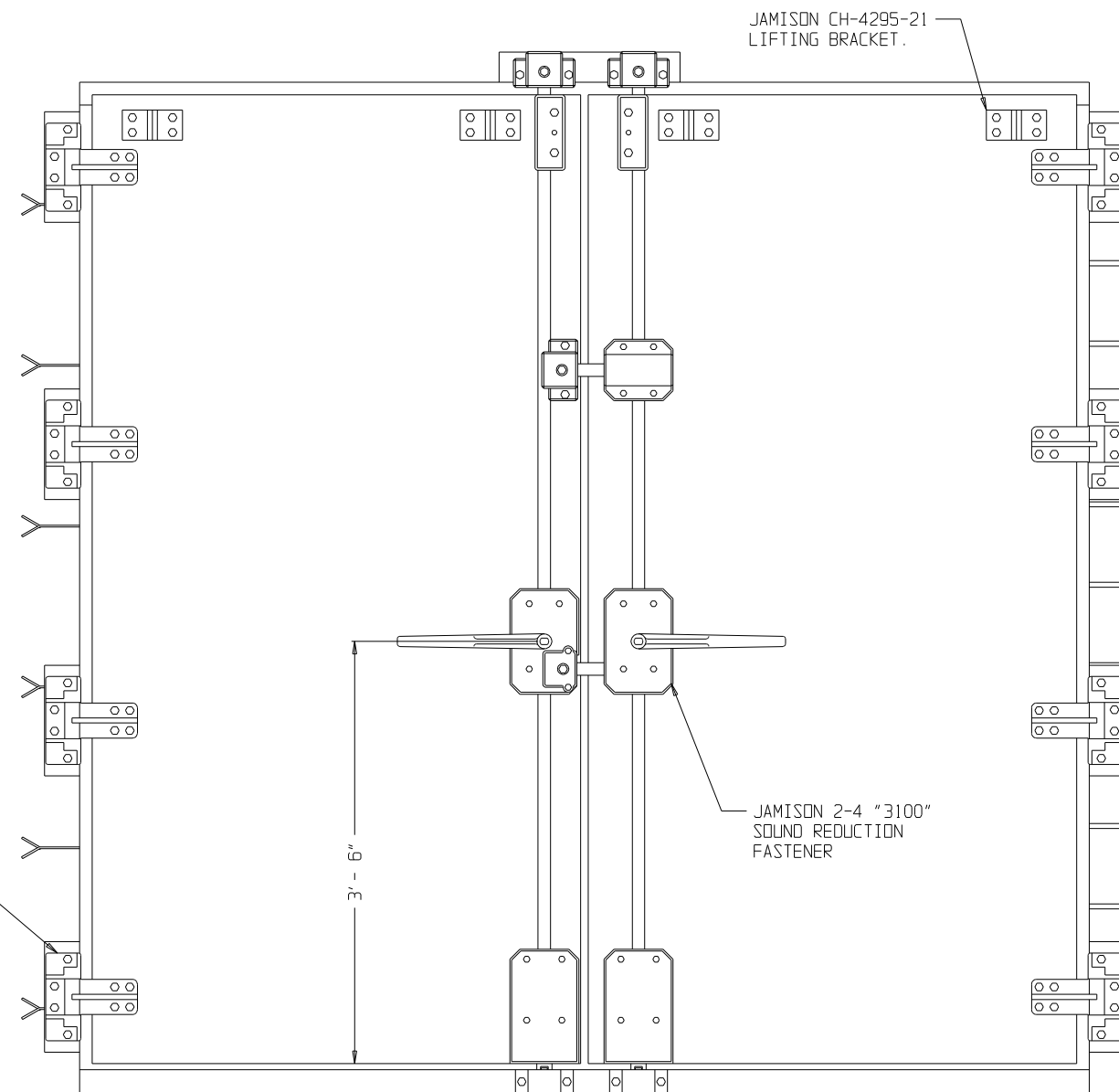

FRONT ELEVATION

RIGHT HAND ACTIVE LEAF SHOWN - LEFT HAND ACTIVE LEAF OPPOSITE

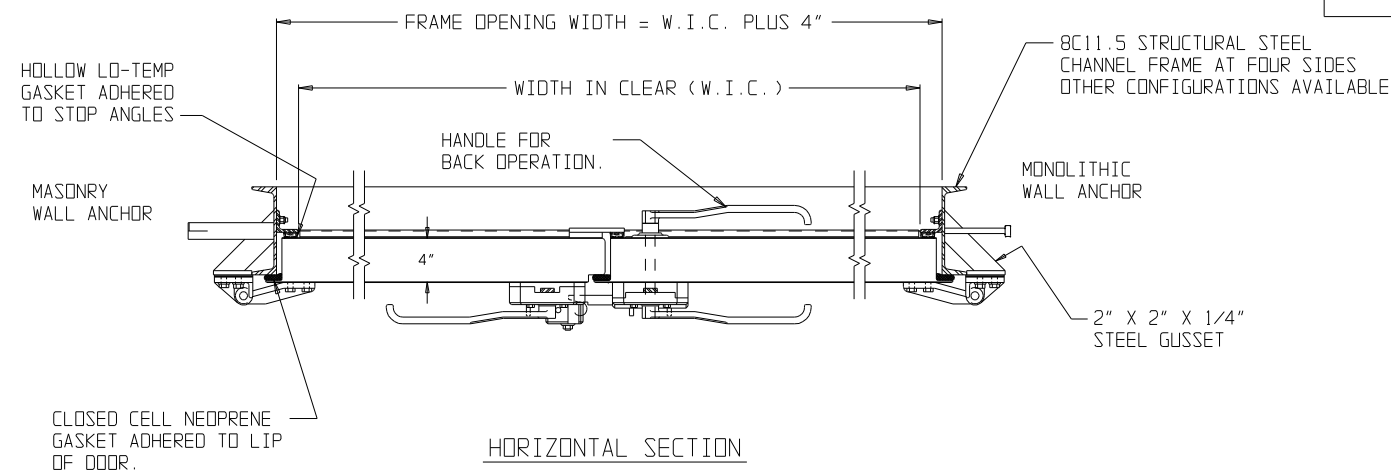

HORIZONTAL SECTION

SCALE(S) NONE		JOB NAME					
DATE	DRAWN	SOUND REDUCTION AND SPECIAL SALES					
6-22-92	W.H.B.						
CHECKED	APPROVED	TITLE	LTR	DATE	BY	SUBJECT	
		STC 53 DOUBLE SWING DOOR				REVISIONS	
JAMISON DOOR COMPANY P. O. BOX 70 HAGERSTOWN, MARYLAND 21741						NO. CH-4424-7	